

RANGE  
**2WD**  
2 WHEEL DRIVE



 **SCL82-17**  
IN-LINE

**SADEV**  
RACING TRANSMISSION

**SADEV**  
RACING TRANSMISSION

RANGE  
**2WD**  
2 WHEEL DRIVE

# SCL82-17

## IN-LINE



The best seller in SADEV's in-line gearbox range, the **SCL82-17** offers an ultra-powerful, affordable solution for multiple uses. Its small size means it can fit into Caterham-type cars. Thanks to its rally, rallycross and track results, the **SCL82-17** is universally recognised for its quality and robustness.

## APPLICATIONS

- › Circuit
- › Hill Climb
- › Drift
- › Rallycross
- › Rally



## TECHNICAL SPECS

6 speed sequential gearbox + 1 reverse gear

Manual sequential gear selection

Direct gear ratio : 19x20 or 19x22

Wide range of ratios available

Straight cut gears

Dog ring gear engagement

Interchangeable gear ratios

High strength carburizing steel

Gear teeth grinded with optimized profile

Shot penning on internal parts

Specific input shaft

Hydraulic clutch bearing (optional)

Reverse lockout cable

Contactless gear position sensor

Contactless flat shift sensor

Splash lubrication system

Fittings to connect external oil cooler

Oil suction screen

Magnetic drain plugs

Painted AS7G aluminum casings

Casing joint faces sealed with O'rings

1315 U-joint or BMW Guibo flex disc flange

Weight (long tail version with gearlever) : 30 Kg - 66 lbs

Weight (short version) : 27 Kg - 59 lbs

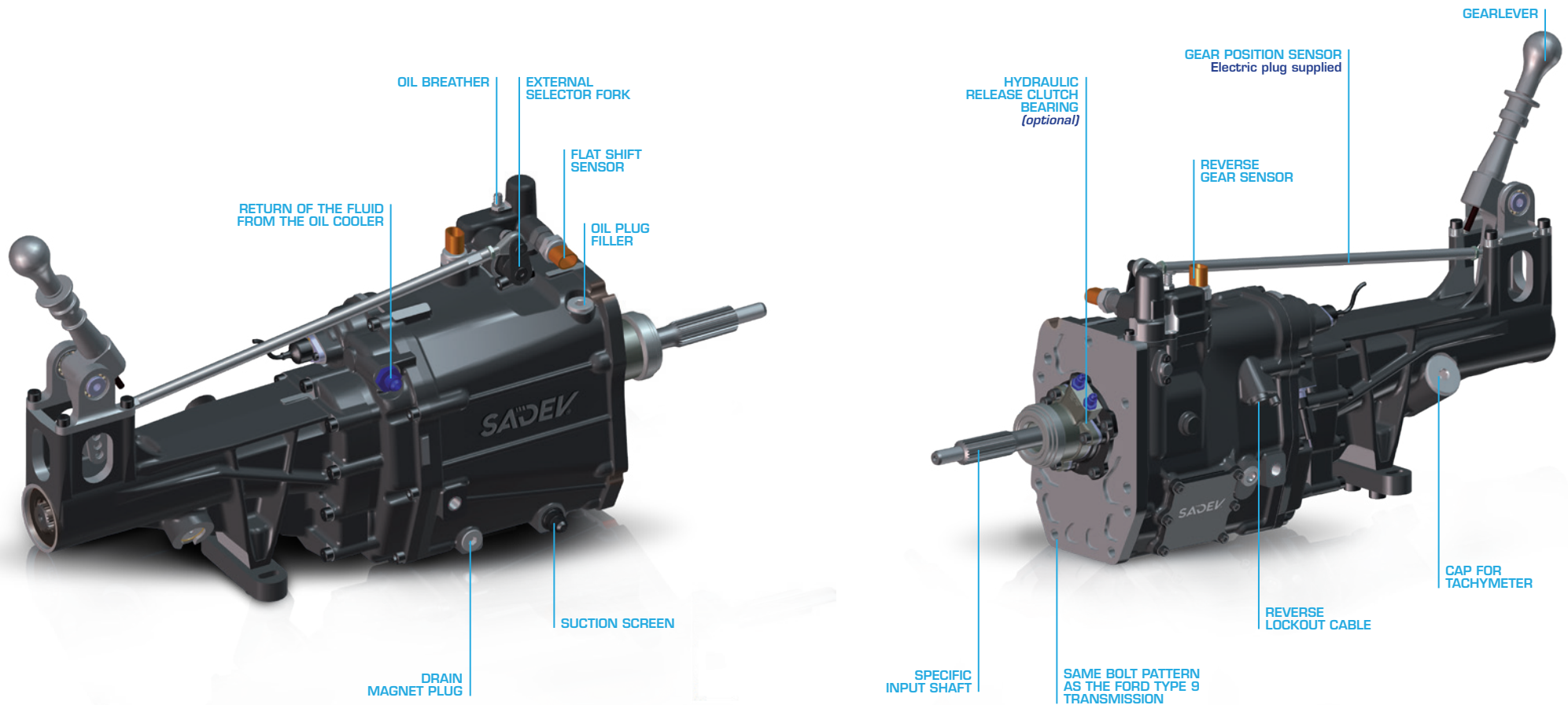

## ACCESSORIES

- › *Mounting plate*
- › *Gear Display*
- › *Hydraulic paddle-shift*

### LONG VERSIONS



LONG TAIL WITH SHORT GEARLEVER  
(CIRCUIT TYPE)

LONG TAIL WITH HIGH GEARLEVER  
(RALLY TYPE)

### SHORT VERSIONS

The SCL82-17 also has a short version. Beside the end cover, the transmission has the exact same features, as described previously.

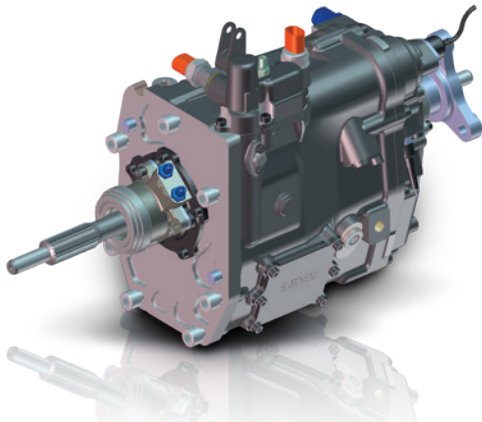

BMW FLEX DISC FLANGE



1315 U-JOINT OUTPUT FLANGE

### COMPACT DESIGN

Our design department has ingeniously created a compact transmission, with 6 gears and a reverse.

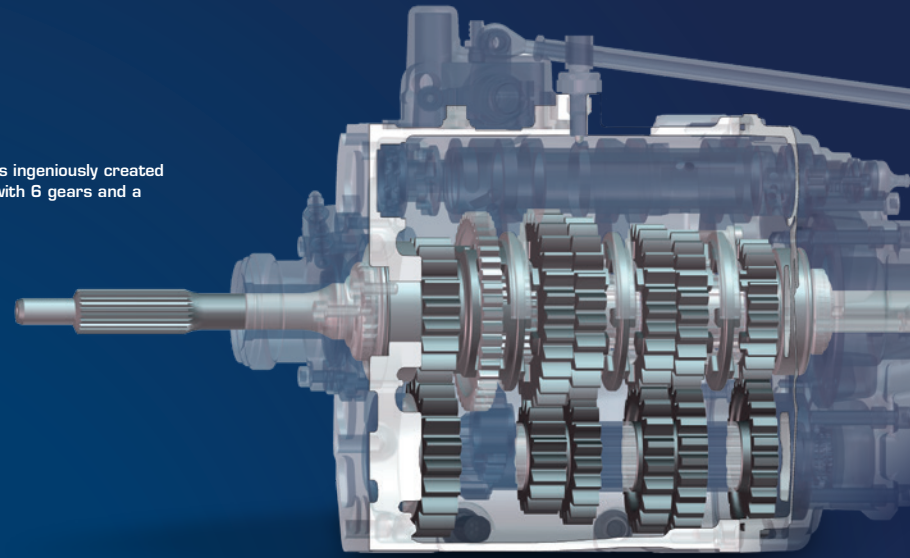

### HYDRAULIC PADDLE-SHIFT

Possibility to connect the SADEV paddle-shift system and to operate the transmission via an external actuator.





## SCL82-17 IN-LINE

- › **Price:** The **SCL82-17** is recognised in the industry for its high quality and low price.
- › **Reliability:** Having sold more than 1,000 gearboxes, the **SCL82-17** continues to prove its high level of reliability in many racing applications.
- › **Dimensions:** With its small footprint, the **SCL82-17** is one of the most compact gearboxes on the market.
- › **Availability:** The real star of the SADEV range, the **SCL82-17** offers many parts available from stock.
- › **Flexibility:** Thanks to its compact design, the **SCL82-17** fits into most vehicles.
- › **Gears:** The **SCL82-17** benefits from optimised gear tooth profiles for maximum efficiency.
- › **Ratio selection:** Optimised clutch and control shaft definition for smoother gear shifting.

### MAXIMUM ENGINE TORQUE

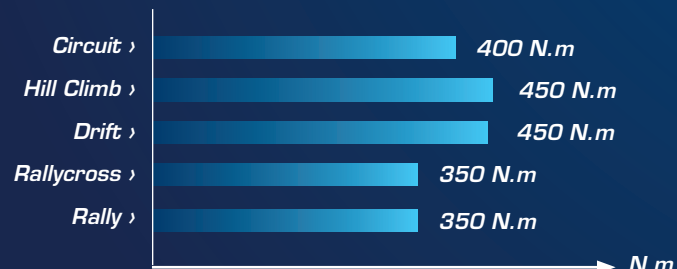



**ONE PASSION:  
VICTORY**

SADEV has an exceptional record in supplying unique engineering to the most prestigious drivers and manufacturers. SADEV's products stand out for their technology, their excellence and their ambition. As precise as they are reliable, these high-tech masterpieces are the key to your victory. SADEV has just one goal: to make sure you win.

FOLLOW US



[WWW.SADEV-TM.COM](http://WWW.SADEV-TM.COM)

6, rue Grand'Montains - 85110 SAINT-PROUANT - FRANCE

Tel: +33 (0)2 51 66 42 68

sadev@sadev-tm.com



**A TEAM AT YOUR SIDE**

- FRANCE** SADEV FRANCE - sadev@sadev-tm.com
- USA** SADEV TRANSMISSIONS, INC. - info.usa@sadev-tm.com
- UK** SWR MOTORSPORT LTD - servicesswrmotorsport@gmail.com
- ITALY** GIEFFE RACING - info@giefferacing.com
- SPAIN** DE LA PUENTE MOTORSPORT - dlpmotorsport@movistar.es
- NETHERLANDS** RACING DEVELOPMENT - info@racingdevelopment.nl
- NETHERLANDS** PETERS AUTOSPORT - bart@petersautosport.nl
- BELGIUM** R TEC - info@rtec.ws
- CZECH REPUBLIC** SADAC - info@sadac.cz
- GERMANY** MTO ENGINEERING - info@mtoengineering.com
- SWEDEN** HANSEN MOTORSPORT - kenneth@hansen-motorsport.se
- DENMARK** GUNNAR AASKOV MOTORSPORT - mail@aaaskov-motorsport.dk
- FINLAND** SET PROMOTION - kalle.pinomaki@setpromotion.com
- SWITZERLAND** CHRISTIAN FERRARI - ferrach@bluewin.ch
- SOUTH AFRICA** CENTURY RACING - julien@centuryracing.co.za
- ARGENTINA** JPO RACING - racingjpo@gmail.com
- BRAZIL** CD MOTORSPORT ENGINEERING - sadev.brasil@gmail.com

